

Lynx Ion + Shunt 350/600
24V/180Ah Lithium Ion Batteries

This publication or parts thereof, may not be reproduced in any form, by any method, for any purpose.

For conditions of use and permission to use this manual for publication in other than the English language, contact Victron Energy B.V.

VICTRON ENERGY B.V. MAKES NO WARRANTY, EITHER EXPRESSED OR IMPLIED, INCLUDING BUT NOT LIMITED TO ANY IMPLIED WARRANTIES OF MERCHANTABILITY OR FITNESS FOR A PARTICULAR PURPOSE, REGARDING THESE VICTRON ENERGY PRODUCTS AND MAKES SUCH VICTRON ENERGY PRODUCTS AVAILABLE SOLELY ON AN "AS IS" BASIS.

IN NO EVENT SHALL VICTRON ENERGY B.V. BE LIABLE TO ANYONE FOR SPECIAL, COLLATERAL, INCIDENTAL, OR CONSEQUENTIAL DAMAGES IN CONNECTION WITH OR ARISING OUT OF PURCHASE OR USE OF THESE VICTRON ENERGY PRODUCTS. THE SOLE AND EXCLUSIVE LIABILITY TO VICTRON ENERGY B.V., REGARDLESS OF THE FORM OF ACTION, SHALL NOT EXCEED THE PURCHASE PRICE OF THE VICTRON ENERGY PRODUCTS DESCRIBED HERE IN.

Victron Energy B.V. reserves the right to revise and improve its products as it sees fit. This publication describes the state of this product at the time of its publication and may not reflect the product at all times in the future.

1 SAFETY INSTRUCTIONS

1.1 In general

Please read the documentation supplied with this product first, so that you are familiar with the safety signs and directions before using the product.

This product is designed and tested in accordance with international standards. The equipment should be used for the designated application only.



WARNING: DANGER OF ELECTRICAL SHOCK

The product is used in combination with a permanent energy source (battery). Even if the equipment is switched off.

The product contains no internal user-serviceable parts. Do not remove the front panel and do not put the product into operation unless all panels are fitted. All maintenance should be performed by qualified personnel.

Never use the product at sites where gas or dust explosions could occur. Refer to the specifications provided by the manufacturer of the battery to ensure that the battery is suitable for use with this product. The battery manufacturer's safety instructions should always be observed.



WARNING: do not lift heavy objects unassisted.

1.2 Installation

Read the installation instructions before commencing installation activities.

Ensure that the connection cables are provided with fuses and circuit breakers. Never replace a protective device by a component of a different type. Refer to the manual for the correct part.

Check before switching the device on whether the available voltage source conforms to the configuration settings of the product as described in the manual.

Ensure that the equipment is used under the correct operating conditions. Never operate it in a wet or dusty environment.

Ensure that there is always sufficient free space around the product for ventilation, and that ventilation openings are not blocked.

Install the product in a heatproof environment. Ensure therefore that there are no chemicals, plastic parts, curtains or other textiles, etc. in the immediate vicinity of the equipment.

1.3 Transport and storage

On storage or transport of the product, ensure that the battery leads are disconnected.

No liability can be accepted for damage in transit if the equipment is not transported in its original packaging.

Store the product in a dry environment; the storage temperature should range from -20°C to 60°C .

1.3.1 Storage instructions of Lithium batteries

Store the Lithium batteries always fully charged.

Check the voltage of the stored Lithium battery periodically. If the voltage is dropped below 24V, recharge it. Because of the battery management electronics there is always a leakage current which will eventually empty the battery. The weekly consumption of the BMS inside a 24V/180Ah battery, when not connected to the Lynx Ion + Shunt, is approximately 2Wh per week.

1.3.2 Storage instructions of a complete system (Lithium batteries with Lynx)

Lithium batteries will permanently damage when fully drained. The system has a small self-discharge which needs to be taken into account when storing the system. It is best to always store the batteries fully charged.

When storing a complete system, make sure that the Lynx Ion + Shunt is set in standby mode (for instructions see chapter 6).

- Standby consumption 24V Systems: 73mW for the Lynx Ion + Shunt (standby).
- Standby consumption 48V systems: 139mW for the Lynx Ion + Shunt (standby).

Two calculation examples:

- A full single 24Volt battery connected to a Lynx Ion + Shunt which is in standby will last approximately 2570 days. The same system, but then automatically switched to standby mode due to under voltage will last approximately 128 days.
- A full 48Volt system with two batteries in series, connected to a Lynx Ion + Shunt which is in standby will last approximately 2700 days. The same system which has automatically disconnected and switched to standby mode due to under voltage will last approximately 135 days.

2 DESCRIPTION

2.1 System components

- One or more **24V 180Ah Lithium-Ion batteries**.
- The **Lynx Power In**. A modular dc bus-bar.
- The **Lynx Ion + Shunt** is the battery management system (BMS) that controls the batteries. A 350/600 Ampere safety relay is inside the Lynx Ion + Shunt.
- The **Lynx Distributor**, a DC distribution system with fuses.
- Optionally, the **Color Control GX**, a digital control panel.

2.1.1 **Battery Management System**

Every individual 24V/180Ah Lithium-Ion battery has an onboard Battery Management System, which monitors and protects the battery on cell level. The Lynx Ion + Shunt communicates with all battery packs via the BMS CAN-Bus and monitors the system as a whole.

2.1.2 **Safety**

When designing the Victron Lithium-Ion battery system, a lot of thought was put into the safety aspect of the system. Each battery is equipped with a BMS to monitor the performance on a cell level. To monitor the global performance we have chosen the Lynx Ion + Shunt. This serves as a master unit and controls the individual batteries. This way the system as a whole can function at its best, ensuring a maximum return. The battery differentiates itself from other batteries thanks to its safety contactor. This breaks the connection between the battery and the rest of the system when the Lynx Ion + Shunt is unable to disconnect the external equipment due to complications.

2.1.3 **User interface: Color Control GX**

The Color Control GX is a digital control panel for the system.

3 LED INDICATIONS

3.1 Lynx Ion + Shunt LED indications

Firmware version 1.22 and higher.

Status LED state	Description
Off	System is in standby mode. Press START button to start up the system
Blinking fast	Initialization.
On	Running
Blinking	Balancing active
Flashing/beeping 1 time	Battery initialization error
Flashing/beeping 2 times	No batteries connected
Flashing/beeping 3 times	Unknown battery connected / battery connected to a running system.
Flashing/beeping 4 times	Different types of batteries connected
Flashing/beeping 5 times	Number of connected batteries incorrect
Flashing/beeping 6 times	Shunt fault
Flashing/beeping 7 times	Battery measure error occurred
Flashing/beeping 8 times	Internal calculation error
Flashing/beeping 9 times	Number of batteries in series incorrect
Flashing/beeping 10 times	Number of batteries incorrect (only used when using static number of battery configuration)
Flashing/beeping 11 times	Not used
Flashing/beeping 12 times	Not used
Flashing/beeping 13 times	Over voltage
Flashing/beeping 14 times	Under voltage
Flashing/beeping 15 times	Over temperature
Flashing/beeping 16 times	Under temperature
Flashing/beeping 17 times	ADC data error
Blinking/beeping fast	Battery BMS error (slave)
Flashing 3 times (no beeping)	Battery BMS warning (slave)
Flashing/beeping 18 times	Pre-Charge error
Flashing/beeping 19 times	Safety contactor error
Flashing 2 times (no beeping)	Over current error on External status or external safety contactor output (appendix A connector B)

3.2 Battery LED indications

Battery status LED	
State	Description
On	BMS Running
Toggle slow	Balancing / BMS stopped
Toggle fast	BMS Error

Battery BMSCAN-Bus error LED	
State	Description
Off	No error in CAN-Bus
Single flash	CAN-Bus passive error
On	CAN-Bus bus-off

Battery BMS CAN-Bus status LED	
State	Description
On	CAN-Bus operational
Toggle slow	CAN-Bus pre-operational
Single flash	CAN-Bus stopped

4 INSTALLATION



This product may only be installed by a qualified electrical engineer.

4.1 Safety precautions

1. Be careful when using metal tools in vicinity of batteries. Dropping a metal tool onto a battery might cause a short-circuit and possibly an explosion.
2. Always use isolated tool when working with batteries.
3. Remove personal metal items such as rings, bracelets, necklaces, and watches when working with a battery. A battery can produce a short-circuit current high enough to melt such items, leading to severe burns.

4.2 Location

The product must be installed in a dry and well-ventilated area, as close as possible to the batteries.

Excessively high ambient temperature will result in a reduced battery lifetime.



The interior of the Lynx components must remain easily accessible after installation.

Try and keep the distance between the Lynx components and the battery to a minimum in order to minimize cable voltage losses.



For safety purposes, this product should be installed in a heat-resistant environment. You should prevent the presence of e.g. chemicals, synthetic components, curtains or other textiles, etc., in the immediate vicinity.

4.3 Mounting

The Lynx system must be mounted on a wall. Every Lynx is provided with holes for mounting. See Appendix B.



4.4 Connecting the Lynx components

The Lynx system must be connected in the following order from left to right:

1. Lynx Power In (optional)
2. Lynx Ion + Shunt
3. Lynx Distributor (optional)

Procedure

1. First remove all fronts from the Lynx components.
2. Connect each Lynx to each other from left to right.
3. Mount the Lynx system to the wall.
4. Connect your chargers and energy consumers at the Lynx Distributor.
5. Install the Victron Lithium-Ion batteries. For installation of the Victron Lithium-Ion battery we refer to chapter 4.7 of this manual.

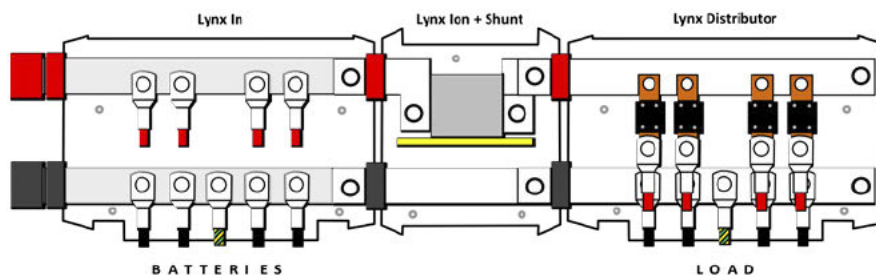

Make sure that the connections between the Lynx units are connected tightly. This prevents series resistance at the connections.

Do not use washers between the connections.

4.5 Connection of the BMS CAN-Bus network

To connect the BMS CAN-Bus communication network you will need:

- CAT5 cable with RJ45 connectors
- Two termination resistors (supplied with the Lynx Ion + Shunt)

Procedure

1. Use connection A of the Lynx Ion + Shunt, top left pair of RJ45 connectors. Connect the other end of the CAT5 cable to the first battery.
2. Then connect it to the second battery (if there is one) with the next CAT5 cable.
3. Repeat this until all batteries are connected.
4. Place a termination resistor in the last connected battery.
5. Place the other termination resistor in the Lynx Ion + Shunt, connection A.

Now the BMS CAN-Bus network is connected.

4.6 Connection of the VE.Can network

The VE.Can network is used to connect the Color Control GX or other VE.Can devices such as the BlueSolar Chargers. These chargers can be digitally controlled by the Lynx Ion + Shunt.

To connect the Lynx Ion + Shunt to the VE.Can network you will need:

- One CAT5 cable with RJ45 connectors
- Two termination resistors (supplied with the Lynx Ion + Shunt)

Procedure

1. Use connection D of the Lynx Ion, the pair of RJ-45 sockets at lower left. Connect the CAT5 cable to the Lynx Ion + Shunt, connection D (see Appendix A).
2. Connect the other end of the CAT5 cable to another VE.Can device such as the Color Control GX.
3. Now place the termination resistors. One in the Lynx Ion +Shunt and one in the other end of the VE.Can network.

4.7 Connection of the Victron Lithium-Ion batteries



Never short a Lithium-Ion battery. There will flow a very high current and can lead to damage of the battery and its environment.



Always use isolated tools when installing batteries.

To connect the Victron Lithium-Ion batteries make sure you have followed all the steps above.

Connection of the Lithium-Ion batteries must be done by the following procedure.

Procedure

1. Connect the '-' connection to cable to the Lynx Power In.
2. Now connect the other end to the first battery.
3. Connect the '+' contact of the battery to the Lynx Power In. Be aware of the little sparking when connecting the cable to the Lynx Power In. (If two batteries are placed in series, connect the '+' contact to the '-' of the next battery).
4. The Lynx Ion +Shunt will now start and is placed in standby state.



Make sure a main switch is connected between the '+' of the battery and the Lynx Power In.



If parallel connections of batteries are made

- Be sure that the battery state-of-charge is equal for each battery.
- Keep wire lengths exactly the same. Otherwise imbalance occurs.

4.8 Using the I/O of the Lynx Ion + Shunt

Allow-to-charge and allow-to-discharge

The most important contacts are 'allow-to-charge' and 'allow-to-discharge'. These are used to control loads and chargers based on the battery state of charge.

These contacts are potential free, and normally open. They are closed when the system is normally working. If the battery is fully charged the 'allow-to-charge' contact will be opened. Now the charger knows that it has to stop charging. If it does not stop charging, the safety contactor will eventually open. This also applies for the 'allow-to-discharge' contact. It is set open when the battery is fully discharged. All consumers have to stop discharging.

See appendix A, connection 'C' for the connections of the allow-to-charge and allow-to-discharge contacts.

External status output

The external status output can be used for external indication similar as the status LED on the front of the Lynx Ion + Shunt.

Two options are possible to connect the external status output.

- Connect a status indicator to connector 'B' pin 1 and 2. This output uses the system voltage.
- Connect a status indicator to connector 'C' pin 8 and 9. This output uses 12V.

See appendix A for the connections details.

External Safety Contactor

See the next paragraph, 4.9.

The external safety contactor output can also be used as an alarm output. If the internal contactor is opened this contact is set LOW(0V) else it is HIGH(system voltage).

External START-button

It is possible to connect an external START-button. This must be connected to pin 7 of connector 'C'. This pin must be switched to GND of the system (pin 9 of connector 'C'). It then has the same functionality as the START-button on the front of the Lynx Ion + Shunt. Use a momentary switch button for this.

I/O Switching limits

Contact	Closed / On	Open / Off
Allow-to-charge signal	When the highest battery cell voltage drops below 3,32V for 10 sec.	When one battery cell voltage reaches 3,52V for 10 sec.
Allow-to-discharge signal	When the lowest battery cell voltage rises above 3,35V for 10 sec.	When one battery cell voltage drops below 2,8V for 10 sec.
Internal Safety contactor	When all cell voltages are between 2,60V and 3,62V.	When one of the cell voltages is above 3,62V or below 2,60V for 20 sec.
External Safety contactor	Same as internal safety contactor	

4.9 Using the Lynx Ion + Shunt with currents above 600A

The internal safety contactor in the Lynx Ion +Shunt is specified for 350A or 600A maximum continuous current (check the type 350 or 600 on the front of the Lynx Ion + Shunt). Up to 1000A is possible by using an external safety contactor, that bypasses the internal safety contactor. The 1000A continuous current limit is the limit of the Lynx Shunt + Shunt.

There are two options to install an external safety contactor:

- Use an external contactor with a 12VDC coil and connect it inside the Lynx Ion + Shunt
- Use an external contactor with a coil voltage equal to the battery system voltage (24/48VDC) and use the External Safety Contact I/O (connector 'B' pin 3 and 4)

Gigavac contactors are recommended because of their low coil power use. Also the Gigavac contactors do not need an extinguishing diode. For use with other contactors like Allbright always use an extinguishing diode.

Contactors which are tested: Gigavac GX16, GX46, GX56, GX66 series.

Contactor Type	12VDC (Recommended)	24VDC	48VDC
Gigavac GX16 600A*	GX16BEB	GX16CEB	GX16FEB
Gigavac GX46 600A	GX46BDB	GX46CDB	GX46FDB
Gigavac GX56 600A	GX56BDB	GX56CDB	GX56FDB
Gigavac GX66 600A	GX66BDB	GX66CDB	GX66FDB

*With the GX16 series the coil contact must be connected with a Deutsch connector (Gigavac order number.: 0697).

Below an overview of how to connect the external contactor to the busbar.

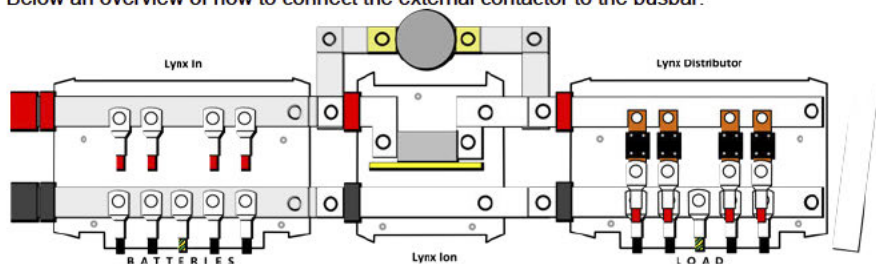

When using an external connector, the control wires of the internal contactor must always be disconnected. These are the wires in blue connector on the upper right. See photo below. Make sure to isolate the end of these wires so they cannot damage the Lynx Ion + Shunt. It is not necessary to remove the internal safety contactor itself.

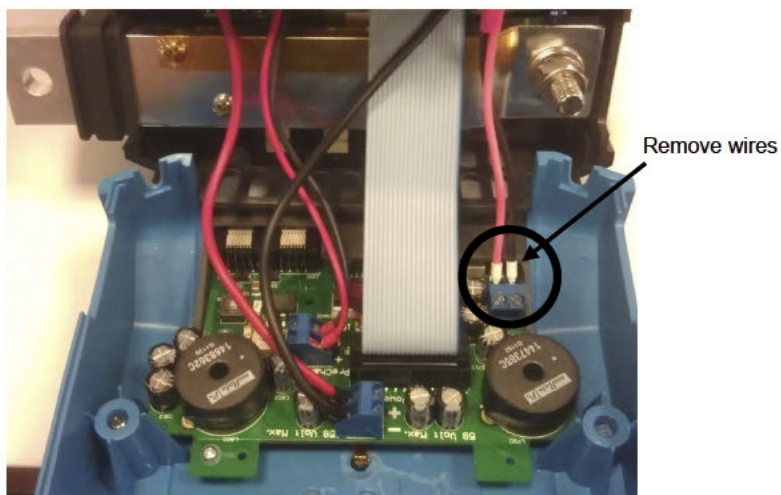

To connect the coil of the external connector it is important to check which coil voltage it has.

Coil voltage	Remarks
12VDC	Connect to the right blue connector inside the Lynx Ion + Shunt. Same as where the internal contactor was connected. check '+' and '-'.
24VDC	Can only be used when connecting to a 24V system. Must be connected to the external contactor connection. (connector 'B' pin 3 and 4).
48VDC	Can only be used when connecting to a 48V system. Must be connected to the external contactor connection. (connector 'B' pin 3 and 4).

Check appendix A for the references of the connections.



If connecting an external contactor to connector 'B' always check if the coil voltage of the contactor is equal to the system voltage. Also check if an extinguishing diode is needed.

5 CONFIGURING A MULTI OR QUATTRO

The Multi is controlled by the Lynx Ion + Shunt, via the allow-to-charge and allow-to-discharge contacts.

State of Charge				
A	B	C	D	E
0%				100%

A	The batteries are discharged too low. The 350A safety contactor in the Lynx Ion will open.
B	The batteries are discharged. The allow-to-discharge signal contact will open. The Multi will switch to 'Charger Only', to prevent further discharging the batteries.
C	OK. The Multi can both charge and discharge the batteries. The allow-to-charge and the allow-to-discharge contacts are closed.
D	The batteries are full. The allow-to-charge contact will open. The Multi will switch to float, to prevent further charging the batteries.
E	The batteries are almost over charged. The 350A safety contactor in the Lynx Ion will open.

Condition A and E are error conditions. Proper configuration of the system will prevent these conditions from occurring. When they occur, correct the situation, and press the start button again to restart the Lynx Ion + Shunt.

Connections

To configure the Multi for BMS support, VEConfigure3 is necessary. See the Support & downloads section at www.victronenergy.com for more information on installing VEConfigure3 and updating the Multi to firmware version xxx200 or higher.

1. Connect the allow-to-charge signal to the AUX input on the Multi.
2. Connect the allow-to-discharge signal to Temp sense input on the Multi. It is not necessary to use a temperature sensor with the Multi, since the batteries have their own internal temperature sensors.
3. Start VEConfigure3, and select the Lithium Iron Phosphate type:

The screenshot shows the 'Charger' configuration tab in VEConfigure3. The 'Battery type' dropdown is highlighted with a red box and contains the text: 'Lithium Iron Phosphate, LiFePo4, batteries. (Also requires an assistant!)'. Other visible settings include:

- Enable charger
- Weak AC input
- Stop after 10 Hr bulk
- Storage mode
- Use tubular plate traction battery curve
- Charge curve: Fixed
- Absorption voltage: 28.40 V
- Float voltage: 26.70 V
- Charge current: 90 A
- Repeated absorption time: 1.00 Hr
- Repeated absorption interval: 7.00 Days
- Absorption time: 2 Hr

4. Configure the Lynx-Ion BMS Support assistant as follows:

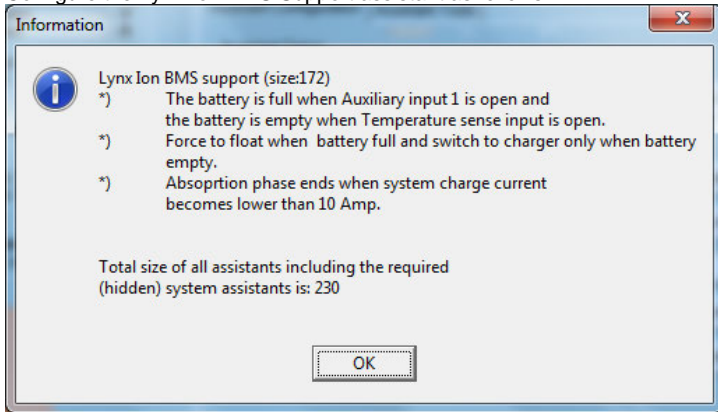

6 FIRST POWER UP

Other than below procedure, no configuration is needed. The battery configuration is automatically recognized.

6.1 Power up procedure

1. Make sure that all energy consumers are switched off before starting up the system.
2. The Lynx Ion + Shunt will pre-charge the system before closing the safety contactor. The Lynx Ion + Shunt will not start if there is more than 10A drawn by the system during pre-charging.
3. Press the START-button on the front of the Lynx Ion + Shunt to start the system.
4. Now the system is being pre-charged. The safety contactor is closed as soon as the voltage rises above 80% of the battery voltage.
5. If the status LED is continuously on, then the system is running and ready for use.

6.2 Power down/reset procedure

Lynx Ion +Shunt to standby mode:

1. Press and hold the START-button until the Lynx Ion goes into standby mode (status LED off).
2. Now the safety contactor is open and the batteries are disconnected from the system.

Reset Lynx Ion + Shunt from error state:

1. Press the START-button for 1 sec.
2. The system will now restart.

6.3 Automatic power-up

The Lynx Ion + Shunt will automatically power-up from standby if a charge voltage on the output is supplied for more than 10 seconds.

7 TEMPERATURE PROTECTION

The Lynx Ion + Shunt constantly monitors the battery temperatures, and protects them according below rules. In case the temperature is outside the limits, it will first signal the chargers and/or loads via the allow-to-charge and allow-to-discharge contacts. It will open the safety contactor if there is no response. In that case you will see the LED blinking in the specified error code (see chapter 3 for details). Press the START-button to restart the system.

High temperature signals:

- Stop charging and discharging at +60°C (allow-to-charge and allow-to-discharge contacts open)
- Charge and discharge alarm at +65°C (safety contactor open)

Low temperature signals:

- Stop charging at -5°C (allow-to-charge contact open)
- Stop discharging at -20°C (allow-to-discharge contact open)

Alarm temperatures:

- Charging alarm at -10°C and current > 10A (safety contactor open)
- Discharging alarm at -25°C and current < -10A (safety contactor open)

8 MAINTENANCE

The Lynx Ion + Shunt does not require specific maintenance. It will suffice to check all connections once a year. Avoid moisture and oil/soot/vapors, and keep the device clean.

9 TECHNICAL SPECIFICATIONS LYNX ION + SHUNT

More details about power consumption are in section 1.3.2.

Supplyvoltage range	9 ... 60VDC
Supply power	
Standby mode	73mW @ 26,2V and 138mW @ 52,4V
Active mode	8,7 W
Operating temperature range	0 ... 50 C
Main safety contactor	350A or 600A DC continuous (depends on Lynx Ion + Shunt type)
Potential free contacts	
Mode	Normally open
Rating	1 A / 60VDC/250 VAC
I/O	
External status output	5 ADC max. Voltage, same as supply.
External relay output	5 ADC max. Voltage, same as supply.
Enclosure	
Dimensions	18.5 x 16.5 x 8.5 cm
Net weight	2.0 Kg
Common Characteristics	Material: ABS; Protection: IP22;

10 TECHNICAL SPECIFICATIONS BATTERIES

Victron Lithium-Ion Battery 24V / 180Ah	
Technology	Lithium-Iron Phosphate (LiFePo4)
Nominal voltage	26,4 V
Nominal capacity	180 Ah
Nominal power	4,75 KWh
Power / Weight ratio	86 Wh/Kg
Charge/Discharge	
Charge cut-off voltage at 0,05C	28,8 V
Discharge cut-off voltage	20 V
Recommended charge/discharge current (0,3C)	54 A
Maximum charge current (1C)	180 A
Maximum discharge current (1,5C)	270 A
Pulse discharge current (10s)	1000 A
Cycle Life @80% DOD (0,3C)	2000
Enclosure	
Common Characteristics	Material: Aluminum and Metal; Protection: IP20;
Battery connections	M10 bolts
Weight	55 Kg
Dimensions (l x w x h in cm)	62,5 x 35,0 x 18,8
Temperature	
Operating temperature during charge	0~45 °C
Operating temperature during discharge	-25~45 °C
Storage temperature	-25~55 °C

APPENDIX A: OVERVIEW LYNX ION + SHUNT

Bottom view

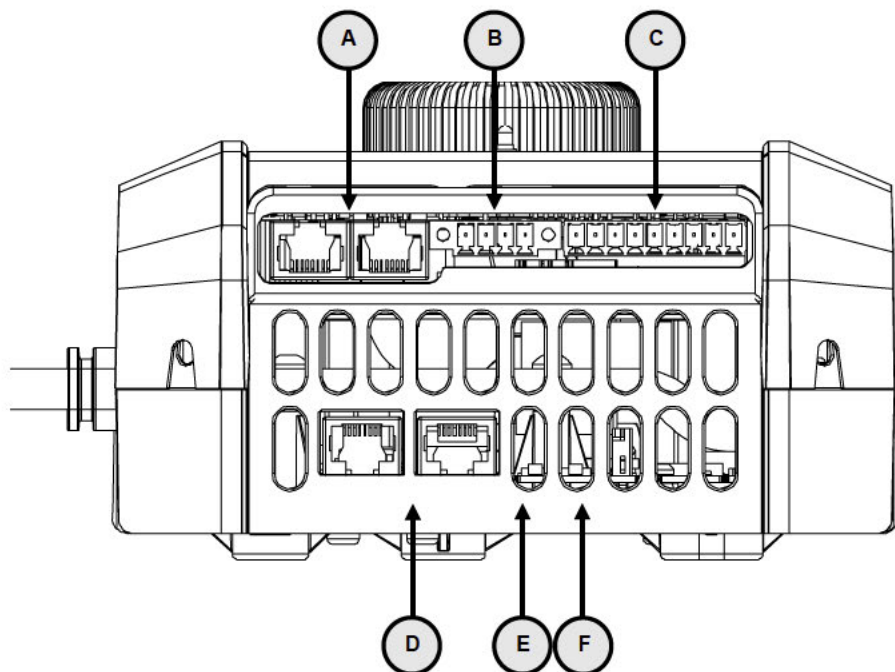

Front view

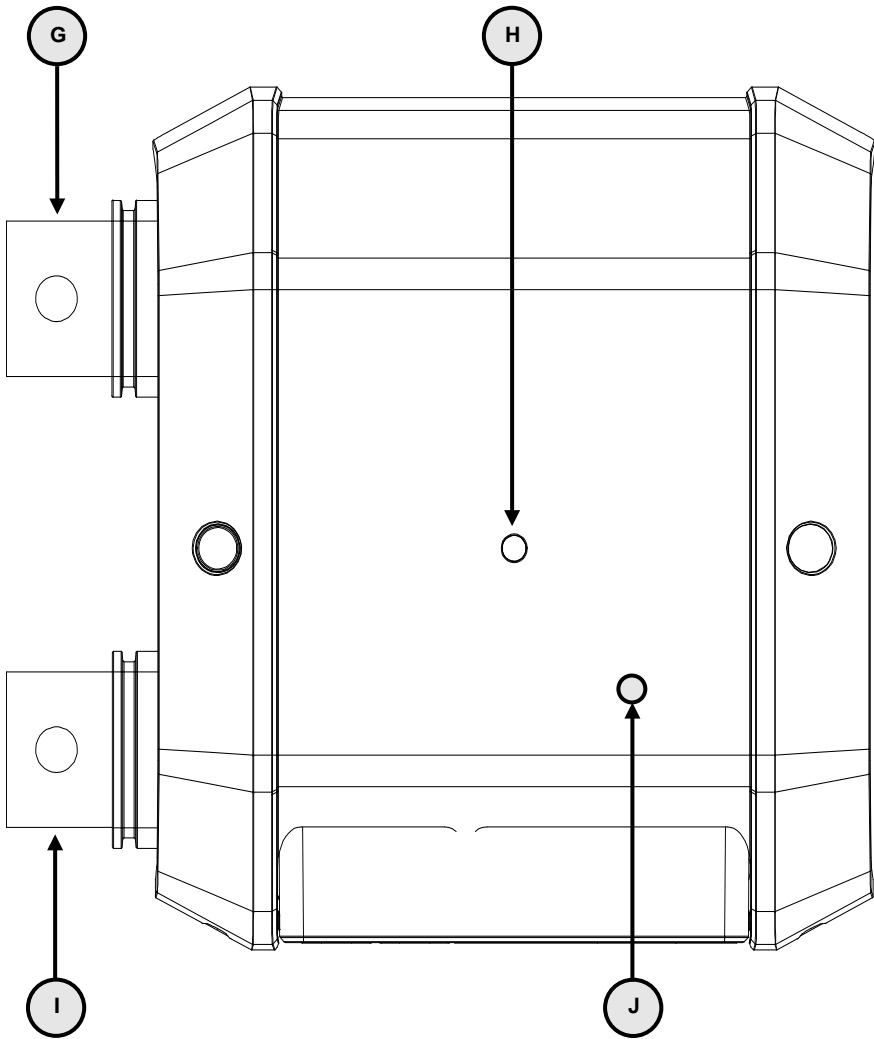

Connector B and C zoomed view

Part descriptions	
A	BMS CAN-Bus connections. CAN-In, CAN-out.
B	Power out connections. Used for External status and external safety contactor.
C	Signal I/O's
D	VE.Can CAN-Bus connections. CAN-In, CAN-out.
E	Hard-reset button.
F	Reserved button.
G	'+' connection for battery.
H	Status LED.
I	'-' connection for battery.
J	START-button.

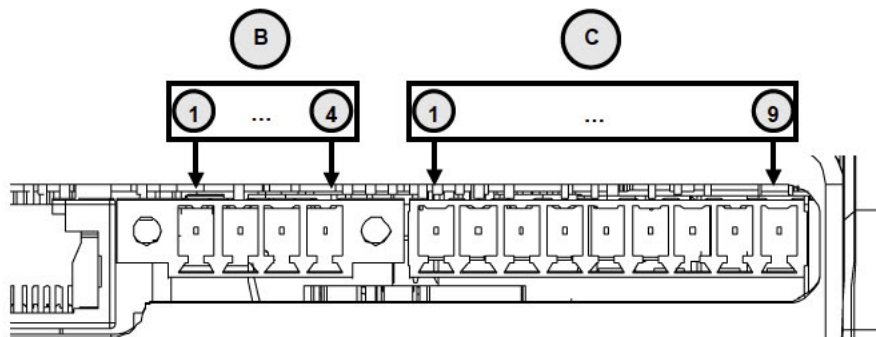

Connector pins and specifications					
Conn.	Pin	I/O	Voltage Max.	Current Max.	Purpose
B	1	Out	+ V System	5 A	External status output
	2		GND		
	3	Out	+ V System	5 A	External safety contactor
	4		GND		
C	1		60 V	1,0 A @ 60 V	Allow-to-charge
	2				
	3		60 V	1,0 A @ 60 V	Allow-to-discharge
	4				
	5		60 V	1,0 A @ 60 V	Future use
	6				
	7	In			External START-button
	8	Out	12 V	140 mA	External status signal
9				GND used for status signal and/or START-button	

APPENDIX B: INSIDE THE LYNX ION + SHUNT

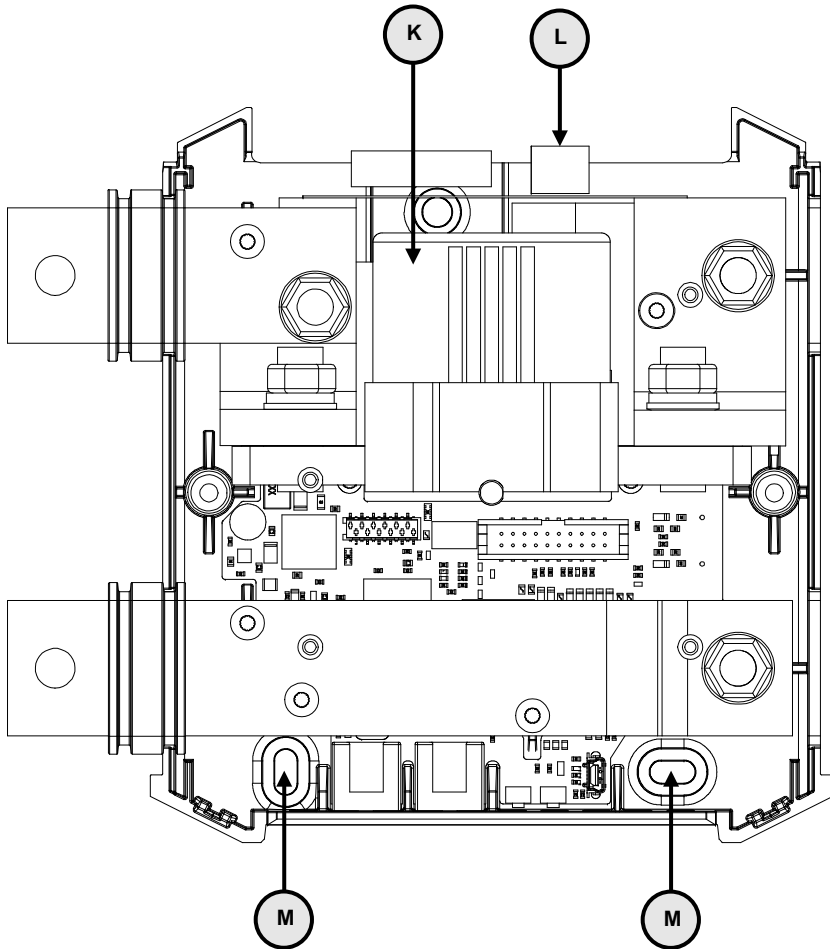

Part descriptions	
K	Safety contactor. 350A or 600A continuous.
L	Pre-Charge fuse 10A.
M	Mounting holes.

APPENDIX C: THE LITIUM-ION BATTERY

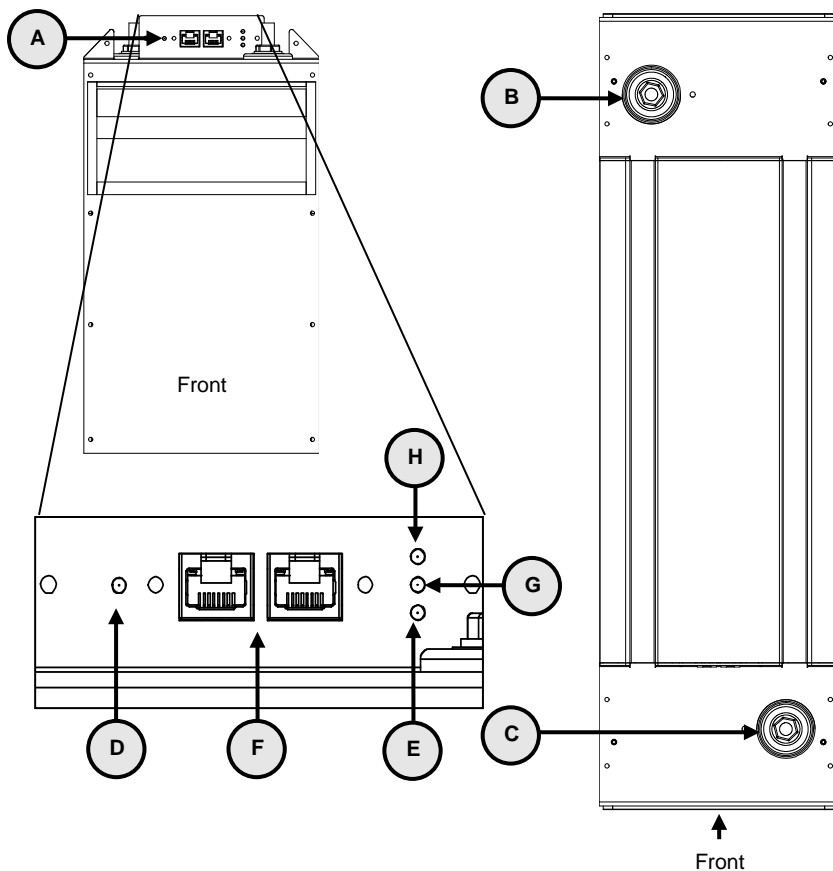

Part descriptions	
A	Connection and status panel.
B	'+' battery connection
C	'-' battery connection
D	Battery power LED
E	Battery status LED
F	BMS CAN-Bus connections
G	BMS CAN-Bus error LED
H	BMS CAN-Bus status LED

Distributor:

Serial number:

Version : 1
Date : 10 June 2014

